

- 32 single-ended or 16 differential inputs
- Autoscanning; continuously digitizes inputs and stores results in dual-ported data registers
- Input ranges from ± 50 mV to ± 10 V or 0 to 25 mA
- Jumper-programmable gains of x1, x10, x100
- Selectable A/D ranges of ± 5 V, ± 10 V, 0 to +10 V
- 40 kHz aggregate conversion rate
- Supports real-time Built-in-Test
- Input connector compatible with both discrete wire and ribbon cables
- Selectable data coding; offset binary or two's complement
- Overvoltage protected inputs
- Low pass input filters: 50 kHz, optional 40 Hz
- Pull-down resistors prevent floating inputs
- 1,000 V analog GND/digital GND isolator

APPLICATIONS

- Instrumentation
- Process control
- Data acquisition
- Voltage measurement
- Factory automation

INTRODUCTION — VMIVME-3125 provides isolated 12-bit analog-to-digital conversion for 32 single-ended analog voltage input channels (16 differential) on a 6U Eurocard for the VMEbus. Selectable gain and A/D ranges support input voltage ranges from ± 50 mV to ± 10 V. Current input option supports 32 single-ended channels with 0 to 20 mA, 4 to 20 mA, and 5 to 25 mA ranges. To minimize system software overhead, all inputs are scanned and digitized continuously at an aggregate sample rate of 40,000 samples per second. Measurement data for each channel is constantly available to the VMEbus through a dual-ported Data Register. For voltage inputs, optional 40 Hz low pass input filters are available to minimize the effects of system noise. The standard unit comes equipped with 50 kHz low pass filters.

A jumper-selectable Programmable-Gain Amplifier (PGA) supports in-line voltage gains of x1, x10, or x100 for all channels. For voltage inputs, full-scale ranges for the A/D Converter are selectable as ± 5 V, ± 10 V, or 0 to +10 V. Data coding is software selectable as either offset binary or two's complement.

Inputs can be jumper configured either as 16 differential voltage channels, or as 32 single-ended voltage or current channels. A single front panel 37-pin subminiature "D" provides connections for all input channels.

Figure 1 illustrates the internal functional organization of the VMIVME-3125 Board.



OPERATING MODE — All 16 or 32 input channels are scanned continuously at the maximum sampling rate, and the resulting data is stored in dual-ported Data Registers for VMEbus access. Scanning starts automatically after any reset operation, and no other programming is required to start the A/D conversion process.

BUILT-IN-TEST FUNCTION (BIT) — Operation of the PGA, ADC, and associated control logic can be verified by selecting the BIT operating mode. In this mode, an internal reference voltage is applied to the input of the PGA, bypassing the analog input multiplexer. All data channels read through the control interface will reflect the selected BIT reference voltage.

FUNCTIONAL CHARACTERISTICS

VMEbus Compliance: This product complies with VMEbus specification ANSI/IEEE STD 1014-1987 IEC 821 and 297, with the following mnemonics:

ORDERING INFORMATION							
June 11, 1996 800-003125-000 C	A	B	C	-	D	E	F
VMIVME-3125	-	0	0	-			
A = Input Option 0 = 50 kHz Input Filter (-3 dB Cutoff Frequency, Voltage Input) 1 = 40 Hz Input Filter (-3 dB Cutoff Frequency, Voltage Input) 2 = 250 Ω 0.01% Termination (High Accuracy Current Input) 3 = 500 Ω 0.01% Termination (High Accuracy Current Input)							
BC = 00 (Options reserved for future use)							
COMPATIBLE CABLE CONNECTOR							
Standard 37-pin subminiature "D" male connector Discrete Wiring: AMP 747916-2 with 206478-4 shell Ribbon Cable: AMP 747306-1							
For Ordering Information, Call: 1-800-322-3616 or 1-205-880-0444 • FAX (205) 882-0859 Copyright © July 1993 by VMIC Specifications subject to change without notice.							

A16:D16/D08 (EO) DTB Slave: 6U form factor

Board Address: The physical address is selected by on-board address jumpers, using VMEbus address lines A07 through A15. The VMIVME-3125 Board occupies 128 bytes of address space, and can be located on any 64-word boundary in the Short I/O (A16) space.

Address Modifiers: Address modifier bits are jumper selected and decoded to respond to Nonprivileged Short I/O access, Supervisory Short I/O access, or to both access privileges.

System Reset: A System Reset establishes the following board status:

- Automatic scanning of all channels
- Front panel diagnostic LED indicator ON
- Offset Binary Data Format

Front Panel System Diagnostic LED: A software-controlled front panel LED turns ON at System Reset, and can be turned OFF under software control to provide an external indication that Built-in-Test has been completed.

Analog Input Data Format: Analog inputs are digitized and stored in 32 dual-ported Data Registers (16 registers for differential operation) as 12-bit right-justified digital values.

Software-selectable data codes are Offset Binary and Two's Complement. In two's complement coding, the sign bit (D11) is extended through the most significant bits of the Data Register (D12 through D15).

SPECIFICATIONS

(At +25 °C and rated power supplies unless otherwise noted.)

INPUT CHARACTERISTICS

Number of Channels: 32 single-ended or 16 differential voltage input channels
32 single-ended current input channels

Voltage Ranges: ±50 mV to ±10 V, bipolar; or 0 to +100 mV, 0 to +10 V unipolar (see Note 1).
Factory configured for ±10 V input range.

Current Termination:

250 Ω	0.01%
500 Ω	0.01%

Current Ranges:

0 to 20 mA
4 to 20 mA
5 to 25 mA

Input Impedance: For voltage input options, 10 MΩ minimum, line-to-line and line-to-common (Note 2)

Common-Mode Voltage (CMV): ±11 V, maximum CMV for differential inputs; zero input signal. CMV is referenced to an analog ground common to all inputs.

Common-Mode Rejection Ratio (CMRR):

Minimum CMRR for differential inputs; 350 Ω source unbalance, DC-60 Hz:

x100:	90 dB
x10:	90 dB
x1:	72 dB

Input-to-VMEbus Isolation: 1,000 VDC

Input Noise:

Maximum noise referred to input, 10 to 1,000 Hz, at 3 σ (Note 3):

x100:	300 μVp-p
x10:	1.0 mVp-p
x1:	4.0 mVp-p

Bandwidth, Each Input: DC-to-Fc, where Fc is 50 kHz for the 50 kHz filter or 40 Hz for the 40 Hz filter option unit.

Input Filter: Single-pole passive low pass filter: -3 dB at 50 kHz or 40 Hz ±20 percent (voltage input options only)

Overvoltage Protection: ±40 V maximum sustained, power applied; ±25 V power removed; ±40 V transient for one second

TRANSFER CHARACTERISTICS

Measurement Resolution: 12 bits

Channel Scan Rate: 40 KSPS (Kilosamples per second) minimum aggregate rate

Voltage Transfer Function:

$$E_{IN} = E_{LO} + E_{FSR} \times \frac{N_{ADC}}{4,096}$$

Where:

E_{IN} = Input voltage
 E_{FSR} = Full-scale input range
 E_{LO} = Lower end of input range
 N_{ADC} = A/D Converter reading

Example:

For an N_{ADC} value of 0B33 HEX (2,867 decimal) in the ± 5 V range:

$$E_{IN} = -5.000 + [10.000 \times (2,867/4,096)];$$

$$= +2.000 \text{ Volts}$$

Current Transfer Function:

$$I_{IN} = \frac{E_{FSR} \times N_{ADC} / 4,096}{R_{TERMINATION}};$$

Where:

I_{IN} = Input current in amps
 E_{FSR} = 10 V unipolar
 N_{ADC} = A/D Converter reading
 $R_{TERMINATION}$ = 250 Ω or 500 Ω option

Example:

For an N_{ADC} value of 0800 HEX (2,048 decimal) with a 250 Ω termination:

$$I_{IN} = [10 \times (2,048/4,096)]/250;$$

$$= 20 \text{ mA}$$

A/D Converter Input Range: ± 5 V, ± 10 V, 0 to +10 V; jumper selectable (Note 1)

A/D Converter Input Gain: x1, x10, x100 (± 0.3 percent, jumper selectable; see Notes 1 and 4)

Accuracy (See Note 4):

Maximum Error:

Voltage Input = ± 0.04 percent reading
 ± 0.03 percent range ± 2.0 mV

Current Input (-200, -300 option) = ± 0.05 percent reading
 ± 0.03 percent range ± 2.44 μ A

Voltage Example:

For a +2.000 V reading in the ± 5 V range:
 Maximum Error = ± 0.8 mV ± 3.0 mV ± 2.0 mV
 = ± 5.8 mV

Stability:

Temperature Drift, per Degree Celsius =
 ± 30 PPM Reading ± 25 PPM Range ± 20 μ V
 Long-Term Drift, per 1,000 hr =
 ± 50 PPM Reading ± 45 PPM Range ± 100 μ V

Interchannel Crosstalk:

-73 dB maximum, DC to 1 kHz with 50 kHz filter
 -67 dB maximum, DC to 1 kHz with 40 Hz filter

BIT Reference Voltage: Software selectable as 0.000 V, +4.980 V, +0.4928 V, 9.91 mV

BIT Reference Accuracy: ± 30 mV ± 30 PPM per $^{\circ}$ C (4.98 VDC)

PHYSICAL/ENVIRONMENTAL

Power Supply Requirements: +5 VDC (± 5 percent) at 2.5 A maximum

Temperature: 0 to +65 $^{\circ}$ C, operating
 -40 to +85 $^{\circ}$ C, storage

Humidity: 20 to 80 percent relative, noncondensing

Altitude: Operation to 10,000 ft (3,048 m)

Cooling: Forced air convection (standard VME slot)

Dimensions: Dual height Eurocard (6U) board

Weight: 0.7 kgm maximum

Input Connector (P3): 37-pin subminiature "D" female connector

1. Input voltage range is determined as:
 INPUT RANGE = A/D RANGE + A/D GAIN.
2. To prevent isolated differential signal sources from "floating" beyond the input CMV range, a pull-down resistance of approximately 22 M Ω is provided between each input pin and analog return.
3. 3σ includes 99.7 percent of all noise in a normal distribution.
4. Indicated accuracy applies after calibration at the selected input voltage range. To maintain full accuracy, calibration should always be performed if the range or gain is changed.

TRADEMARKS

The VMIC logo is a registered trademark of VME Microsystems International Corporation. Other registered trademarks are the property of their respective owners.

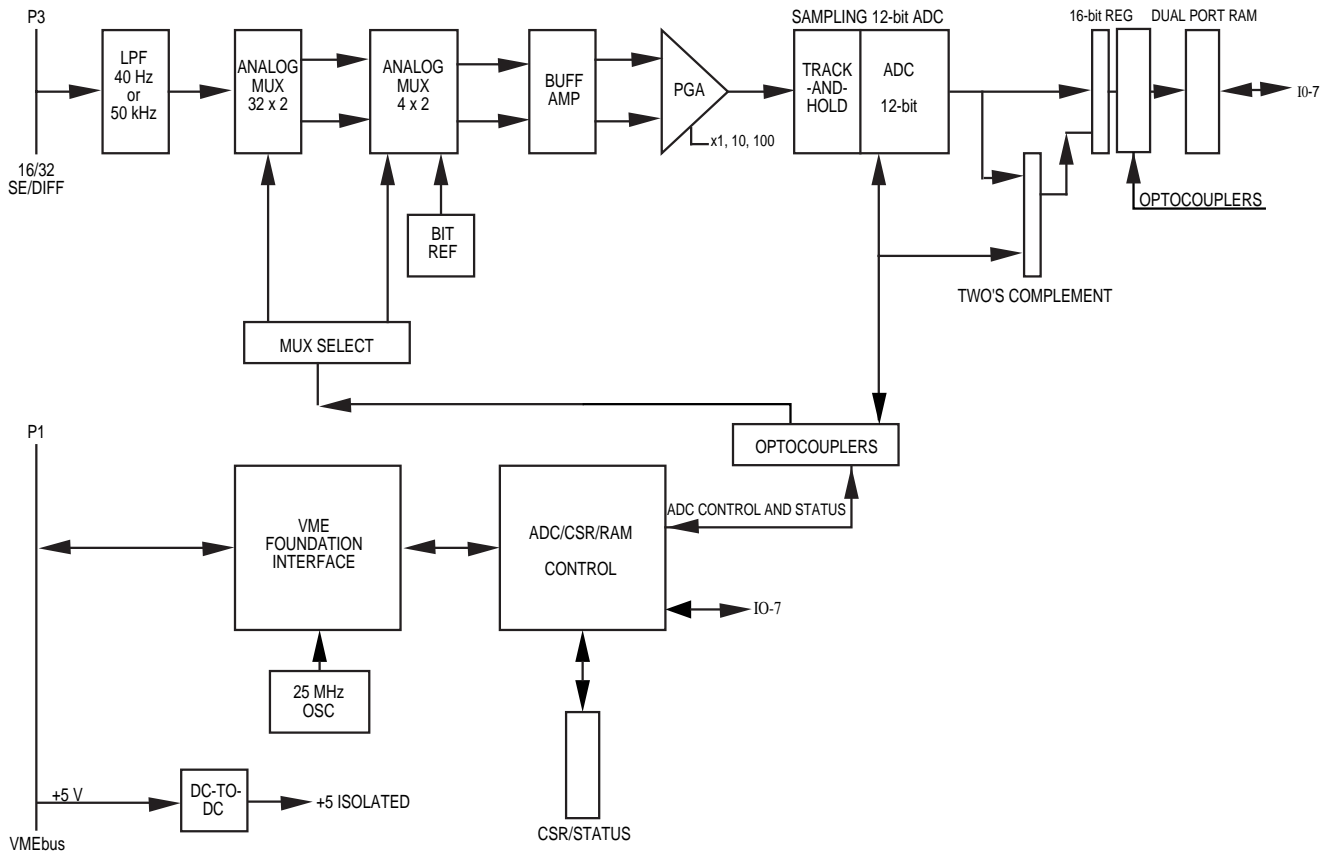

Figure 1. VMIVME-3125 Functional Block Diagram