

- 8 or 16 isolated input channels with active guards
- 16-bit data
- 1,500 VDC (1,000 VAC) isolation, input-to-input and input-to-VMEbus
- High input impedance 10 MΩ with power on or off
- Digitizer per channel
- Standard input voltage range of ±50 mV to ±10 V, software-selectable on channel-by-channel basis
- Optional input voltage range of ±5 mV to ±1 V, software-selectable on channel-by-channel basis
- Option for current mode input
- Software-controlled bandwidth, 0.05 to 26 Hz (6-pole low pass filters implemented with internal DSP)
- DSP-based offset and gain correction in real-time
- DSP supported E²PROM stores calibration coefficients (no trim pots)
- Conversion rate of 100 SPS (samples per second) per channel
- RTD excitation under software control (200 mA/400 mA per channel)
- Open transducer detection under software control
- Supported by VMIC's I/O controllers

APPLICATIONS

- Power plant monitoring
- Machine monitoring
- Data acquisition
- RTDs, strain gauges, and thermocouples

INTRODUCTION — The VMIVME-3126A is an 8- or 16-channel, high-resolution, isolated Analog-to-Digital Converter (ADC) board. For normal voltage mode, the inputs accept isolated signals in the range of ±50 mV to ±10 V. The low-level voltage option accepts signals of ±5 mV to ±1 V. An option is provided for current mode inputs. Input-to-input and input-to-VME isolation are provided.

Each input is sampled and digitized by a dedicated 24-bit ADC per channel. The Digital Signal Processor (DSP) performs calibration and filtering using 32-bit arithmetic and the most significant 16 bits are provided to the user.

Automatic scanning of all inputs is executed on power up after the board performs self-test. The self-test includes reading and writing to the Random Access Memory (RAM), digitizing a reference voltage on each ADC, comparing the result to the actual digital value expected, and loading calibration and filter coefficients into the Digital Signal Processor (DSP). Accuracy is optimized with the use of internal corrections for gain and offset that are applied in real-time and determined during the calibration mode.

FUNCTIONAL CHARACTERISTICS

(At 25 °C and rated power supplies, unless otherwise stated.)

VMEbus Access and Compliance: Response to address modifiers is jumper-selectable as:
 A24 or A16 address space
 Supervisory or user privilege, or both
 D16/D8 (EO) DTB Slave
 6U form factor

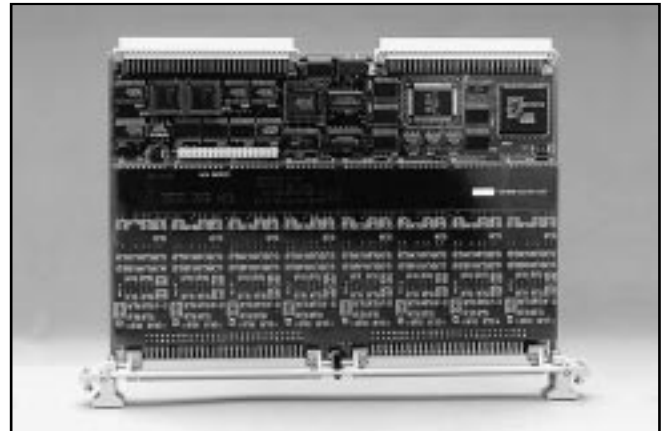

Board Address: The base VMEbus address is set by configuration of a jumper field. A jumper exists for each of the addresses A23 through A8; thus, the address space occupied by this board is 256 bytes.

OPERATING MODES

Sample Mode: Board powers up sampling all inputs simultaneously after a successful self-test.

Ordering Options							
October 15, 1998 800-103126-000 F	A	B	C	-	D	E	F
VMIVME-3126A	-		0	-			
A = Number of Input Channels 0 = 8 Channels 1 = 16 Channels B = Input Type 0 = Voltage Input Board 2 = Reserved 1 = Current Input Board 3 = Low-Level Voltage Input Board C = Front Panel 0 = STD Front Panel 1 = Ruggedized Front Panel (See Notes 1 and 2)							
Connector Data (Notes 1 and 2)							
Style	Recommended Connecting Component		P3 and P4 I/O Connectors				
64-pin Discrete	Mating Connector (96-pin Discrete)		AMP 925286-1 (3)				
Wire	Female Crimp Contacts (64-pin Discrete)		AMP 530151-6 (4)				
	Connector Housing (for 64-pin Connectors)		Harting 09 02 064 0501				
Notes							
1. It is recommended that twisted, shielded pairs be used to connect to the VMIVME-3126A. 2. For the ruggedized connection: Order VMIVME-3126A-AB1, Cable Assembly (VMIC part number 360-010061-010), and Terminal Block Assembly Model BT01 (VMIC part number VMIACC-BT01-002). 3. Center row not connected. 4. AMP Crimp tool part number 90301-2.							
For Ordering Information, Call: 1-800-322-3616 or 1-256-880-0444 • FAX (256) 882-0859 E-mail: info@vmic.com Web Address: www.vmic.com Copyright © August 1995 by VMIC Specifications subject to change without notice.							

Calibration Mode: Calibration mode is entered by setting a bit in the Board and Status Register (BSR). Each channel is calibrated by the DSP using up to seven external calibration voltage inputs. Gain and offset coefficients are stored in the DSP for real-time correction. The user can set another bit in the BSR to write the coefficients to the E²PROM. Users also have the ability to enter their own gain and offset coefficients.

Configuration Mode: Configuration mode is entered by setting a bit in the BSR. Each channel can be individually configured for range, filter frequency, data output format, and type of input (Normal, RTD Excitation, Open Transducer Detect).

Autozero Mode: Autozero Mode is entered by setting a bit in the BSR. In this mode, each input is disconnected from the field connection via an electronic switch. A ground reference is connected, digitized, and compared to an ideal ground reading. The offset coefficients are adjusted to eliminate this difference. This technique provides a method of compensating for temperature variations without requiring a calibration operation.

Self-Test: Self-Test is run automatically after a system or software reset. The on-board RAM and each ADC is tested. Status Registers indicate success or failure of each of these components.

Front Panel Indicator: Program-controlled front panel LED illuminates RED on power up, calibration, and reconfiguration of channels. The LED is turned off after successfully completing the above mentioned modes.

Board Identification: A Board Identification Register (BIR) contains the VMIVME-3126A identification code.

VMIC SOFTWARE PRODUCTS — VMIC has a wide range of software aimed at developers who are incorporating VMIC CPUs, I/O boards, and workstations into systems. Windows NT® OS, MS-DOS®, and VxWorks are the most common operating systems supported.

The IOWorks® software family is a set of software components that can work together or separately to provide a total development and control environment for VMEbus systems. Programming can be done in ladder logic, the C language, or VMIC's Universal Control Language for I/O (UCLIO™). The popular Windows NT OS is used to provide powerful multitasking, multithreading, and multiprocessor operation. VMIC's Visual Soft Logic Control™ software (VMISFT-9510) provides a total environment for developing, monitoring, and controlling using the components of IOWorks.

INPUT CHARACTERISTICS

Input characteristics are listed for voltage inputs. Current mode characteristics can be calculated by assuming a 400 Ω resistor across the inputs with 25 mA maximum current.

Number of Input Channels: 8 or 16 isolated 2-wire channels with an active guard pin per channel.

Isolation Voltage: Channel-to-channel, channel-to-VME; 1,500 VDC, 1,000 VAC

Input Ranges (Software Controlled Per Channel):

Normal Voltage Board: Bipolar: ±50 mV, ±100 mV, ±500 mV, ±1 V, ±5 V, ±10 V
Unipolar: 0 to 50 mV, 0 to 100 mV, 0 to 500 mV, 0 to 1 V, 0 to 5 V, 0 to 10 V

Low-Level Voltage Board: Bipolar: ±5 mV, ±20 mV, ±50 mV, ±100 mV, ±500 mV, ±1 V
Unipolar: 0 to 20 mV, 0 to 50 mV, 0 to 100 mV, 0 to 500 mV, 0 to 1 V

Differential Common-Mode Input Range: ±5 V, common-mode plus signal

Common-Mode Rejection: 130 dB, DC to 60 Hz, F_c = 0.05 Hz (HI and LO connected to common signal, AGND connected to signal return).

DSP Filters (Software Controlled Per Channel): 0.05 to 26 Hz low pass, 6-pole. Approximates Bessel response.

Accuracy: (Percent FSR) (Note 1)

Option - A0C

Full-Scale Range	Accuracy
± 10 V, ±5 V, 0-10 V, 0-5 V	0.0030%
± 1 V	0.0076%
± 500 mV, ±100 mV, 0-1 V, 0-500 mV	0.012%
± 50 mV, 0-100 mV	0.017%
0-50 mV	0.060%

Option - A3C

Full-Scale Range	Accuracy
±1 V, ±500 mV, ±100 mV, ±50 mV, 0-1 V, 0-500 mV	0.006%
±20 mV, 0-100 mV	0.008%
0-50 mV	0.012%
0-20 mV	0.023%
±5 mV	0.035%

Stability: Temperature drift, per degree Celsius = ± 5 PPM Reading ± 6 PPM full-scale ± 2 μ V. Offset errors due to temperature can be eliminated by autozeroing.

Input Noise: Typical and maximum input noise is shown in Table 1. In this table, inputs HI, LO, and AGND are shorted together at front panel connector, and noise units are μ V RMS.

Bandwidth, Each Input: DC to F_c , where F_c is 0.05 to 26 Hz (Note 2)

Input Impedance: 10 M Ω , minimum, power either ON or OFF. (Does not apply to boards equipped with the current-input option.)

Interchannel Crosstalk: -150 dB maximum at 1 kHz, $F_c = 1$ Hz

Isolation-Mode Rejection: 160 dB at 60 Hz, $F_c = 1$ Hz (HI, LO, and AGND of channel connected to common signal with signal return connected to VME ground)

Overvoltage Protection: ± 25 V line-to-line

RTD Excitation (Software Controlled Per Channel): 200 μ A/400 μ A, ± 20 percent maximum, 20 PPM/ $^{\circ}$ C typical

Open Transducer Detection (Software Controlled Per Channel): 200 μ A, functional on all ranges below ± 1 V (0 to 1 V)

Current Termination Resistor: 400 Ω resistor placed across the inputs. ± 25 μ A maximum sustained input current. (Calibration inputs are specified in current units instead of voltage units.)

TRANSFER CHARACTERISTICS

Resolution: 16 bits

Input Sampling: All inputs are sampled simultaneously

Integral Nonlinearity: ± 0.005 percent maximum from best straight line

Channel Sample Rate: 100 SPS per channel; 1,600 SPS maximum aggregate (800 SPS for 8-channel board)

Data Coding: Software programmable, two's complement or straight/offset binary

DATA BUFFER MEMORY

Buffer Size: 16 contiguous 16-bit data words

Access Time: 400 ns from DS to DTACK

VMEbus Access: D8 or D16

PHYSICAL/ENVIRONMENTAL

Temperature Range:
0 to +65 $^{\circ}$ C (standard VME slot), operating
-40 to +85 $^{\circ}$ C, storage

Humidity: 10 to 80 percent relative, noncondensing

Altitude: Operation to 10,000 ft (3,048 m)

Cooling: Forced air convection (standard VME slot)

Dimensions: Double height Eurocard (6U) board, 160 x 233.35 mm

Weight: 700 g, maximum

Input Connectors: Two 64-pin DIN connectors

Power Requirements: +5 VDC ($\pm 5\%$) at 2.8 A maximum

MTBF: 119,700 Hours (217F)

1. Indicated accuracy applies after calibration at the selected input voltage range.
2. Default cutoff frequency is 26 Hz.

TRADEMARKS

UCLIO and Visual Soft Logic Control are trademarks and IOWorks and the VMIC logo are registered trademarks of VMIC. MS-DOS and Windows NT are registered trademarks of Microsoft Corporation. Other registered trademarks are the property of their respective owners.

Table 1. Noise in mV RMS as a Function of Filter Setting and Input Range

Option - A0C Typical								
Range	26 Hz	10 Hz	4 Hz	1.7 Hz	0.7 Hz	0.3 Hz	0.12 Hz	0.05 Hz
±10 V	220	142	110	75	50	25	18	10
±5 V	110	73	50	35	15	3	3	1
±1 V	30	18	13	9	6	3	1.5	1
±500 mV	20	11	8	6	4	2	0.5	0
±100 mV	18	8	6	4	2	1	0.5	0
±50 mV	15	7	5	3	2	0.9	0.3	0
0-10 V	220	130	90	65	40	20	8	0
0-5 V	105	60	45	30	25	15	4	0
0-1 V	25	15	10	7	5	2	0.6	0
0-500 mV	18	10	6	4	3	2	0.6	0
0-100 mV	15	7	5	3	2	1.5	0.6	0
0-50 mV	15	7	4	3	2	1.5	0.6	0
Maximum								
±10 V	300	180	170	170	170	170	170	130
±5 V	150	110	90	90	80	80	80	60
±1 V	60	40	30	30	25	25	25	15
±500 mV	50	40	25	20	15	15	12	8
±100 mV	50	30	20	15	10	5	4	3
±50 mV	50	30	20	12	10	5	3	1
0-10 V	300	160	130	100	100	100	100	20
0-5 V	140	100	90	80	70	70	70	15
0-1 V	60	50	20	15	15	15	10	7
0-500 mV	40	25	15	10	8	8	8	6
0-100 mV	40	15	15	5	5	4	3	2
0-50 mV	50	15	15	10	8	5	2	2

Table 2. Noise in μ V RMS as a Function of Filter Setting and Input Range

Option - A3C Typical								
Range	26 Hz	10 Hz	4 Hz	1.7 Hz	0.7 Hz	0.3 Hz	0.12 Hz	0.05 Hz
±1 V	31	20	15	13	8	4	2	1.5
±500 mV	17	10	7	5	4	1.5	0.7	0.6
±100 mV	6	3	2	2	1.5	1	0.7	0.6
±50 mV	6	3	2	1.5	1	0.7	0.5	0.2
±20 mV	5	3	2	1.5	1	0.6	0.4	0.2
±5 mV	5	3	2	1.5	1	0.6	0.3	0.2
0-1 V	30	17	12	8	6	5	3	0.3
0-500 mV	16	9	6	4	3	2	2	0.2
0-100 mV	5	3	2	1.5	1	0.8	0.4	0.3
0-50 mV	5	2	2	1	0.8	0.6	0.3	0.2
0-20 mV	5	2	2	1	0.7	0.5	0.3	0.2
Maximum								
±1 V	40	25	20	20	20	17	17	17
±500 mV	25	15	10	10	8	8	3	1
±100 mV	10	8	6	4	4	3	2	1
±50 mV	10	7	6	3	2	1.5	1.5	0.8
±20 mV	10	7	6	3	2	1.5	1.5	0.8
±5 mV	10	7	6	3	2	1	0.8	0.6
0-1 V	40	25	15	12	10	10	10	7
0-500 mV	20	15	9	8	6	6	6	6
0-100 mV	12	8	6	4	2	2	0.9	0.9
0-50 mV	10	6	4	3	1.5	1.5	1	0.7
0-20 mV	10	6	4	3	1.5	1.5	1	0.7

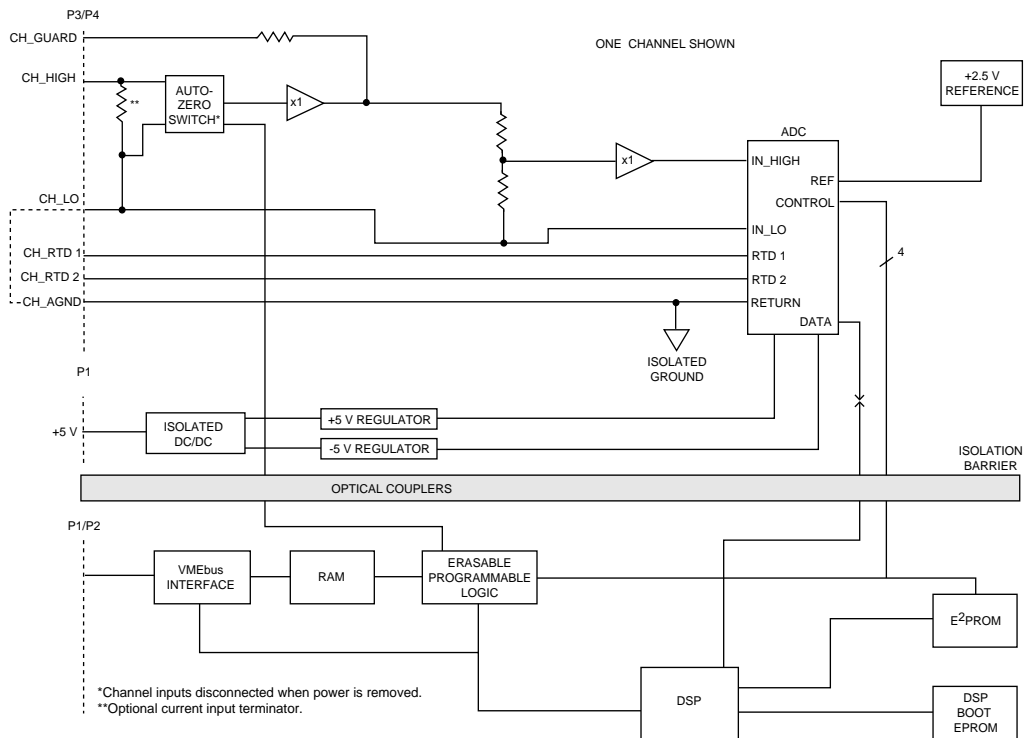
Figure 1. VMIVME-3126A Block Diagram