

ZAT-DV **DVS /x**

DESCRIPTION

DVS units are designed for connection of galvanically separated serial communication lines through VME bus to control system ZAT-2000 MP. The units enable connection of up to 8 serial lines of RS-232, RS-485 or RS-422 type. The unit consists of basic module (identified as D-VSBx) and maximally three extension modules (identified as D-VSEx). An overview of possible combinations is stated in Table 1.

Each module contains two serial lines and is equipped with presence of feeding voltage signalling (green LED). The view to front panel of the unit is in Fig. 1 (unit DVS/17 – 4xRS-232, 4xRS-485).

nal connector. The modules D-VSEx convert signals of this internal bus into front panel of the unit. Structure of module D-VSBx is indicated in Fig. 3.

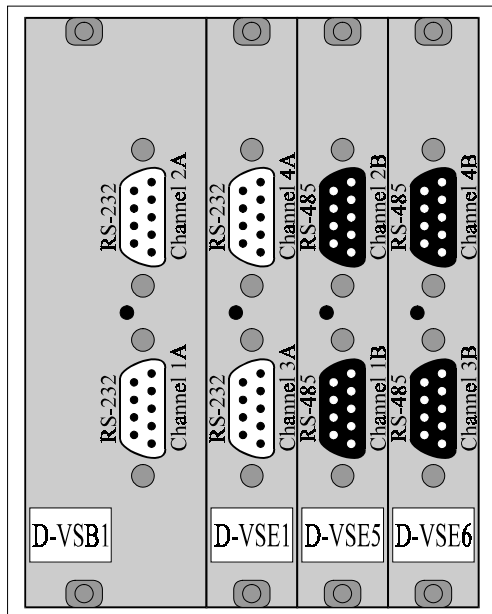

Fig. 1: Front panel of the unit

Block diagram of the units is in Fig. 2. Quantity and type of serial lines vary according to the unit type.

The module D-VSBx consists of carrier VMOD-2, card with galvanical separation D-VIS1 and 1 or 2 (according to the unit type) special communication cards (identified as PB-SIO4(A)). These cards contains HW interface for 4 serial lines. The serial lines are galvanically separated (out of VME bus, this galvanical separation is common one for single card PB-SIO4(A)). The module VSBx has led all the galvanically separated serial lines in its inter-

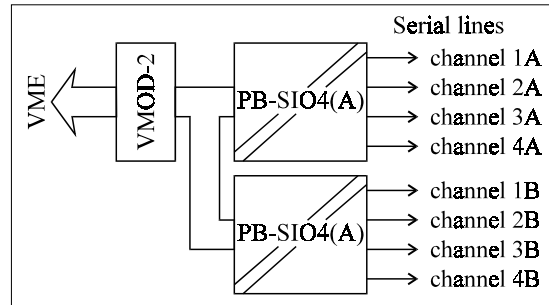

Fig. 2: Unit block scheme

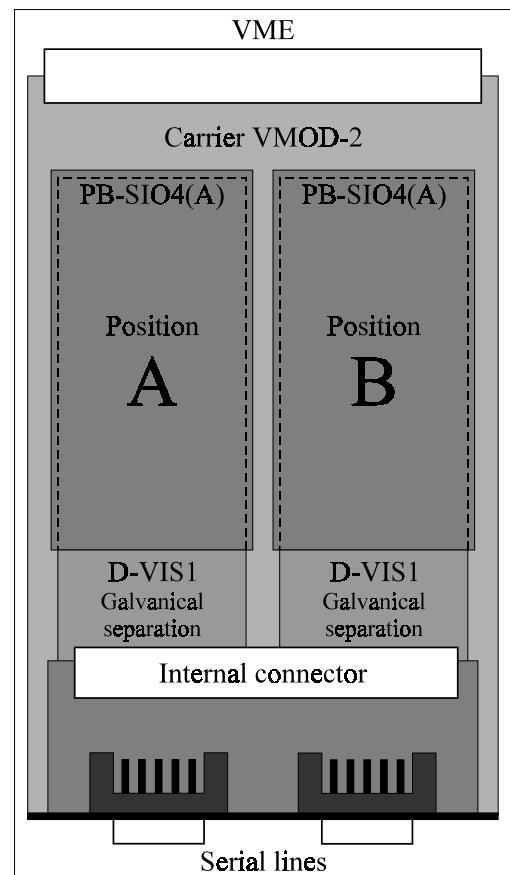

Fig. 3: Module D-VSBx (view from above)

Serial lines are counted in a way indicated in Figure 1. For one module PB-SIO4(A) are counted in the scope 1-4 according to unit type. The letter A or letter B identifies the module PB-SIO4(A), which services given serial line.

Individual serial lines are lead into 9-pin connectors of CANNON type.

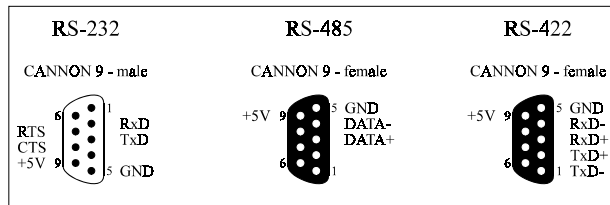

Fig. 4: Connection of unit connectors

Each serial line has lead voltage +5 V into pin 9 for free usage. Maximal consumption in single unit must not exceed 200 mA per one module PB-SIO4(A) (it means for the example of unit DVS/17 in Fig. 200 mA for RS-232 and 200 mA for RS-485).

TECHNICAL PARAMETERS

Transmission type	Asynchronous, full duplex
Max. transfer rate	19,2 kBaud

Serial lines of RS-232 type enable HW control of data flow by means of signals RTS and CTS.

DATA FORMAT

Number of bits	5 8 plus parity
Parity	Even, odd, none
Number of STOP bits	1; 1,5; 2

OTHER PARAMETERS

Feeding	+5 V, max. 2,5 A, VME
Working temperature	0 °C ÷ +70 °C
Storing temperature	-20 °C ÷ +85 °C
Insulation strength	500 V
Humidity	5 ÷ 95 % (non-condensing)
VME connector	DIN 41612 C, 96 pin
<u>Width of front panel :</u>	
– basic module	8 TE (40,6 mm)
– extension module	4 TE (20,3 mm)

At units with serial lines of RS-485 or RS-422 types there is possible to terminate optionally these serial lines according to following Fig. 5.

The units are delivered without termination of serial lines.

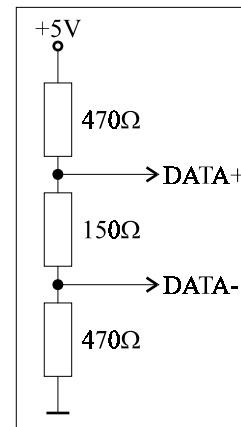

Fig. 5: Termination of serial lines RS-485/422

Termination is implemented by means of jumpers interconnection in the module PB-SIO4A according to following table:

Serial line No.1	B62	B53 Position 1-3	B54 Position 1-3
Serial line No.2	B63	B55 Position 1-3	B56 Position 1-3
Serial line No.3	B64	B57 Position 1-3	B58 Position 1-3
Serial line No.4	B61	B59 Position 1-3	B60 Position 1-3

Status of other jumpers is unchanged. Placement of jumpers is in Fig. 6.

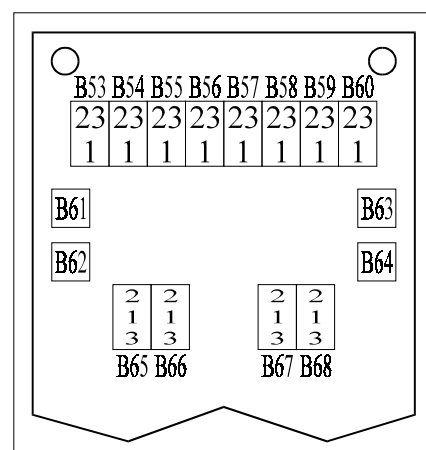

Fig. 6: Placement of jumpers in module PB-SIO4A

Detailed information about modules VMOD-2, PB-SIO4(A) could be find out in user manuals for these modules, which are delivered by producer – PEP Modular Computers.

